

THE INFORMATION DISCLOSED HEREIN CONSTITUTES PROPRIETARY INFORMATION AND WAS ORIGINATED BY AND IS THE PROPERTY OF OLIVER WELDING & FABRICATING INC. EXCEPT FOR RIGHTS EXPRESSLY GRANTED TO THE UNITED STATES GOVERNMENT, OLIVER WELDING & FABRICATING INC. RESERVES ALL PATENT, PROPRIETARY, DESIGN, USE, SALE, MANUFACTURING AND REPRODUCTION RIGHTS THERETO.

5th Attach the Diagonal as seen on pg 5

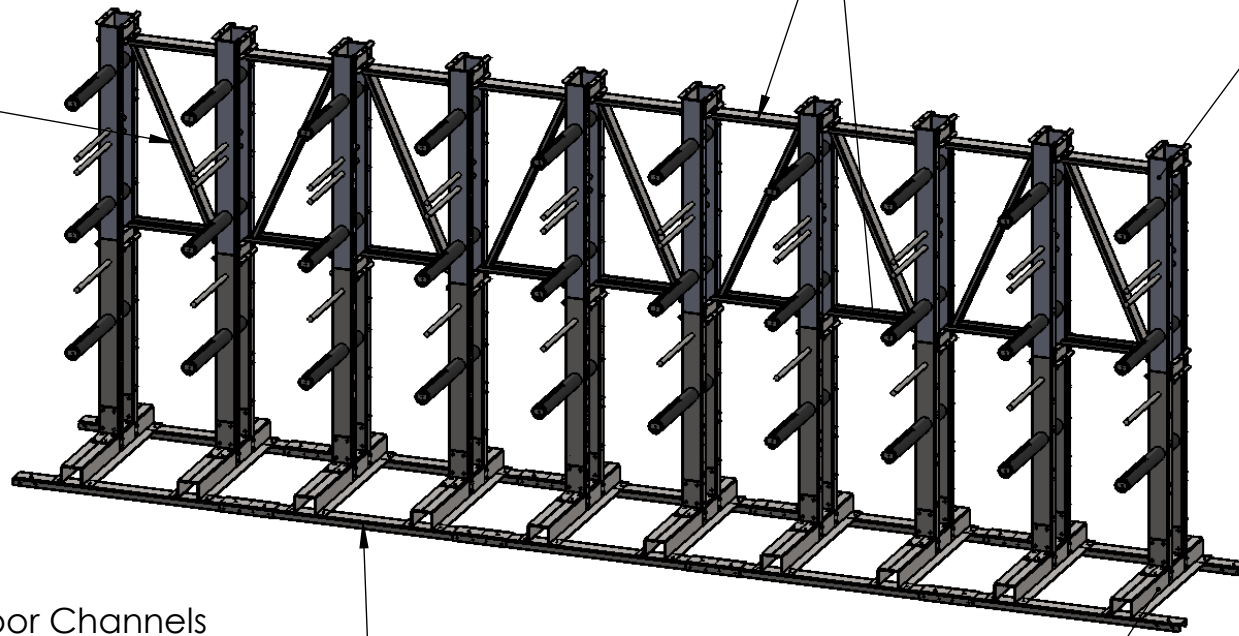

4th Attach Top Ties
18 places, as seen on pg 4

3rd Drop The Station Assemblies Into the Bases



1st Assemble the Floor Channels & Floor Channel Couplers as seen on pg 2

2nd Bolt the 10 Base Assembly together and attach to the Floor channels as seen on pg 3

UNLESS OTHERWISE SPECIFIED TOLERANCES ARE		NAME	DATE	  Oliver Welding & Snyder Machine Company 30 Avery Street Ipswich, MA 01938 (978) 356-4488 www.oliverwelding.com
3 PLACE ±	.005	DRAWN		
2 PLACE ±	.01	CHECKED		
1 PLACE ±	.03	ENG APPR.		
FRACTIONS ±	-	MFG APPR.		
ANGULAR ±	1/2°	Q.A.		
DIMENSIONS ARE IN INCHES DIMENSIONS IN BRACKETS ARE IN MILLIMETERS		MATERIAL		TITLE: Paper Rack Assy Instructions
COMMENTS:		FINISH		SIZE DWG. NO.:
				SCALE: DO NOT SCALE DRAWING SHEET 1 OF 5

THE INFORMATION DISCLOSED HEREIN CONSTITUTES PROPRIETARY INFORMATION AND WAS ORIGINATED BY AND IS THE PROPERTY OF OLIVER WELDING & FABRICATING INC. EXCEPT FOR RIGHTS EXPRESSLY GRANTED TO THE UNITED STATES GOVERNMENT, OLIVER WELDING & FABRICATING INC. RESERVES ALL PATENT, PROPRIETARY, DESIGN, USE, SALE, MANUFACTURING AND REPRODUCTION RIGHTS THERETO.

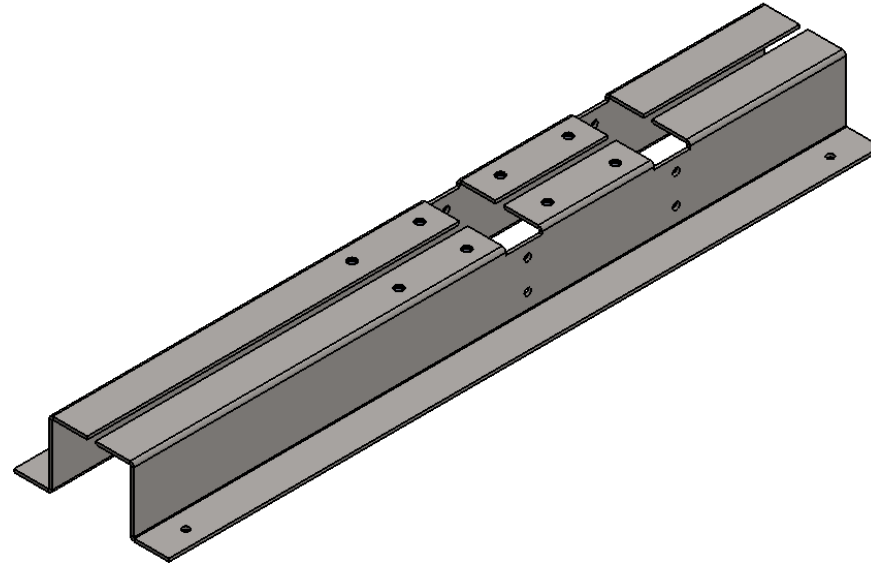

Base Assembly

UNLESS OTHERWISE SPECIFIED:		NAME	DATE	 <i>Oliver Welding & Fabricating Inc.</i> 30 Avery Street Ipswich, MA 01938 (978) 356-4488 www.oliverwelding.com
DIMENSIONS ARE IN INCHES	DRAWN			
TOLERANCES:	CHECKED			TITLE:
FRACTIONAL ±	ENG APPR.			
ANGULAR: MACH ± BEND ±	MFG APPR.			
TWO PLACE DECIMAL ±	Q.A.			<h1>Paper Rack Assy Instuctions</h1>
THREE PLACE DECIMAL ±	COMMENTS:			
INTERPRET GEOMETRIC TOLERANCING PER:				SIZE DWG. NO. REV
MATERIAL				A
FINISH				SCALE: 1:12 WEIGHT: SHEET 3 OF 5
DO NOT SCALE DRAWING				

THE INFORMATION DISCLOSED HEREIN CONSTITUTES PROPRIETARY INFORMATION AND WAS ORIGINATED BY AND IS THE PROPERTY OF OLIVER WELDING & FABRICATING INC. EXCEPT FOR RIGHTS EXPRESSLY GRANTED TO THE UNITED STATES GOVERNMENT, OLIVER WELDING & FABRICATING INC. RESERVES ALL PATENT, PROPRIETARY, DESIGN, USE, SALE, MANUFACTURING AND REPRODUCTION RIGHTS THERETO.

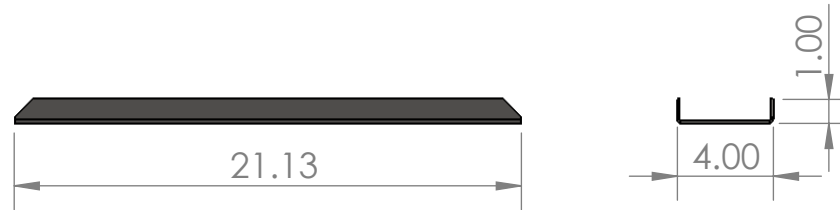
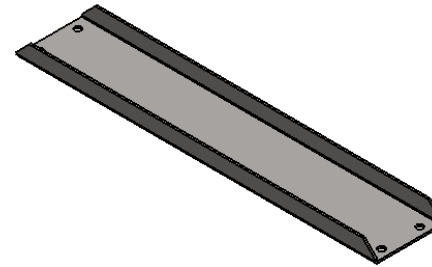

Top Ties

UNLESS OTHERWISE SPECIFIED:		NAME	DATE	 <i>Oliver Welding & Fabricating Inc.</i> 30 Avery Street Ipswich, MA 01938 (978) 356-4488 www.oliverwelding.com
DIMENSIONS ARE IN INCHES TOLERANCES: FRACTIONAL ± ANGULAR: MACH ± BEND ± TWO PLACE DECIMAL ± THREE PLACE DECIMAL ±		DRAWN		
INTERPRET GEOMETRIC TOLERANCING PER:		CHECKED		TITLE:
MATERIAL		ENG APPR.		
FINISH		MFG APPR.		SIZE DWG. NO. REV
DO NOT SCALE DRAWING		Q.A.		A
		COMMENTS:		SCALE: 1:8 WEIGHT: SHEET 4 OF 5

THE INFORMATION DISCLOSED HEREIN CONSTITUTES PROPRIETARY INFORMATION AND WAS ORIGINATED BY AND IS THE PROPERTY OF OLIVER WELDING & FABRICATING INC. EXCEPT FOR RIGHTS EXPRESSLY GRANTED TO THE UNITED STATES GOVERNMENT, OLIVER WELDING & FABRICATING INC. RESERVES ALL PATENT, PROPRIETARY, DESIGN, USE, SALE, MANUFACTURING AND REPRODUCTION RIGHTS THERETO.

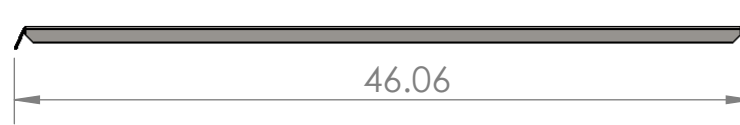
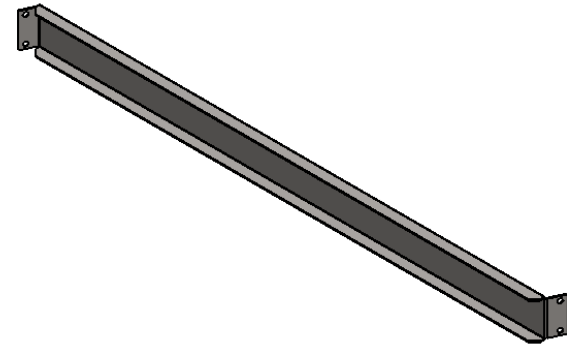

Diagonal

UNLESS OTHERWISE SPECIFIED: DIMENSIONS ARE IN INCHES TOLERANCES: FRACTIONAL ± ANGULAR: MACH ± BEND ± TWO PLACE DECIMAL ± THREE PLACE DECIMAL ± INTERPRET GEOMETRIC TOLERANCING PER: MATERIAL FINISH DO NOT SCALE DRAWING		NAME	DATE	 <i>Oliver Welding & Fabricating Inc.</i> 30 Avery Street Ipswich, MA 01938 (978) 356-4488 www.oliverwelding.com
	DRAWN			
	CHECKED			TITLE:
	ENG APPR.			Paper Rack Assy Instuctions
	MFG APPR.			SIZE DWG. NO. REV
	Q.A.			A
	COMMENTS:			SCALE: 1:12 WEIGHT: SHEET 5 OF 5